

*Antique brass is difficult to photograph, changing appearance with viewing angle. For more accurate depiction see page 7.*

The Gilbert® 2000GT Flying Venus™ is thin and beautiful. More importantly, it sets the standard for wall scone ILT effectiveness.

Gilbert® Flying Venus™ sconces create an elegant ambiance for your favorite room, while secretly providing 24-hour, non-stop, silent-capture of filthy disgusting flies. The beautiful light attracts them. The glueboard secretly traps them.

Features two F20T12BL350 (or equivalent) 20 watt insect attractant lamps. Replace annually.

**Dimensions: ONLY 2 3/4" DEEP!  
24 3/4" Wide x 11 1/2" High.**

Depth slopes 2 3/4" (at top) to 1 7/16" (at bottom point).  
Installation: Mount anywhere. So thin, ADA rules do not apply.

Textured Vinyl Weight: 6.72 lbs. Ship Wt: 9 lbs.  
Polished / Antique Brass Weight: 8.16 lbs. Ship Wt: 11 lbs.

One Year Warranty (excluding lamps & glueboards)

**2000GT FLYING VENUS™ CHOICES:** Choose decorative power cord (6 ft., 115v grounded) or hard-wire version. We highly recommend ordering the optional hard-wire version for the aesthetic, cordless look. Universal knockouts and keyhole mounting slots provided on all versions.

All Flying Venus™ ILTs are available in four beautiful finishes: Polished Brass, Antique Brass, Textured Black or Textured White vinyl-coated aluminum.



### 2000GT Holds Standard Glueboard

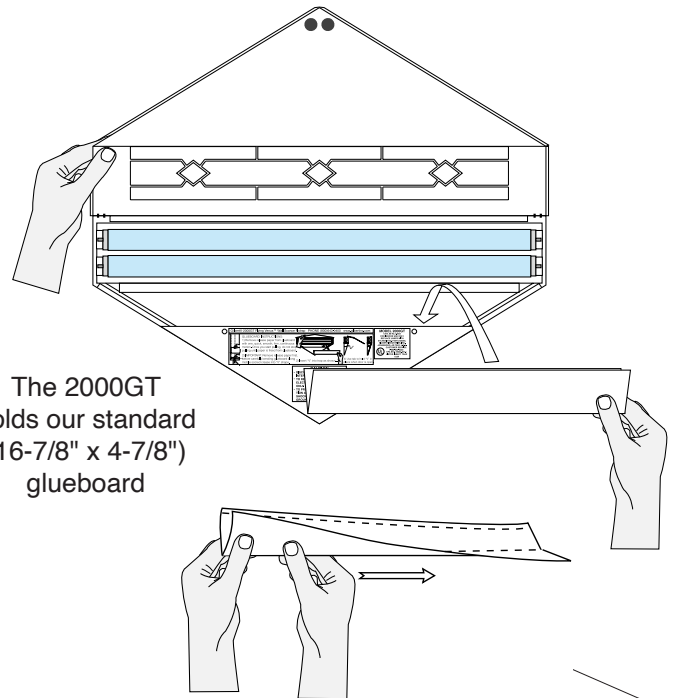

The 2000GT holds our standard (16-7/8" x 4-7/8") glueboard

Gilbert® glueboards are scored for bending into a "V" shape for a perfect, space saving fit in the 2000GT Flying Venus™.

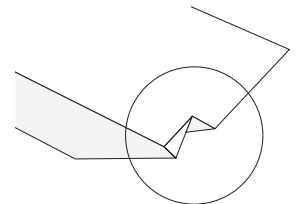

If necessary, to prevent lamp heated glue from oozing out the end of the "V", bend 1/2" up at each end (forming a tray to contain glue).

See Also: [gilbertinc.com/glueboard.htm](http://gilbertinc.com/glueboard.htm)

# Gilbert® Manufacturing Plant

JONESBORO, AR, USA



**Don Gilbert**

**Company Founder  
Insect Light Trap Pioneer  
(1923-1993)**



Gilbert® has produced leading designs since Don Gilbert built the first, truly professional ILT in 1967. Gilbert® invented low mounting, corner mounting, multi-purpose portability, and superior catching ability.

Yet, it was not his trap designs, but his philosophy that was the true key to his success. Don's idea of ILTs, as only one tool in his bag, to be applied with a sincere desire to help customers in any way he could, was simple and honest. His efforts were so successful, Gilbert® was granted a registered trademark.

Don's son, David, now president, joined his father in 1981 and began applying what he knew of science to ILTs, picking his father's brain, doing his own research.

Gilbert® continues to offer the best in both glueboard and electrocuting ILTs and to lead the way away from gimmicks, toward true professionalism. Keep us informed of your experiences. Together, we will continue the fight for sincere, scientific use of professional ILTs.

All Gilbert® Professional ILTs are C-UL-US Listed and exceed all known codes - FDA, USDA, EPA, etc. We use only high quality component parts and warranty every Gilbert® trap.



**PHONE (800) 643-0400**  
MON - FRI 7AM - 3:30PM CT

**See: [gilbertinc.com](http://gilbertinc.com)**

For The Most Up-to-Date Info Available!

Gilbert Industries, Inc., 5611 Krueger Drive, Jonesboro, AR 72401-6818  
PHONE: (870) 932-6070 FAX: (870) 932-5609