

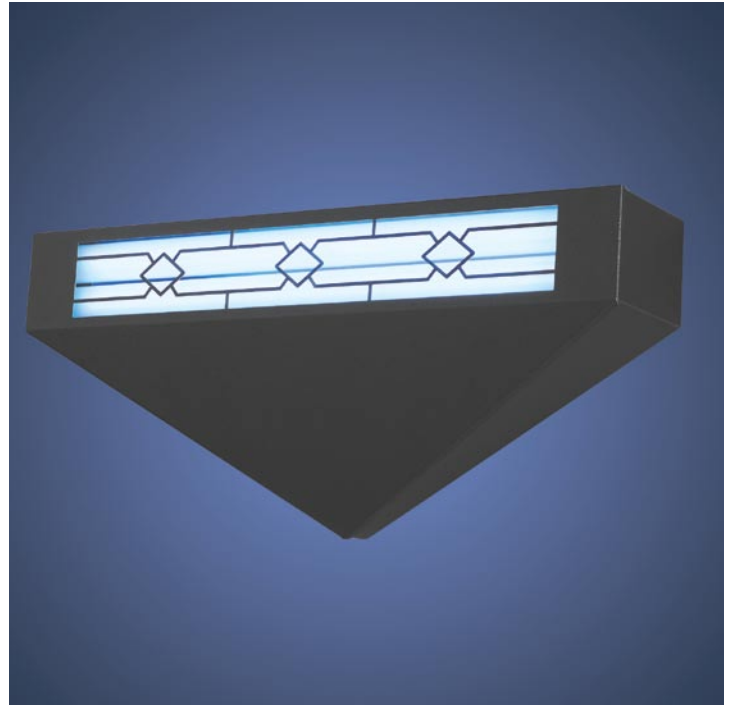

2002GT *Voluptuous* Flying Venus™

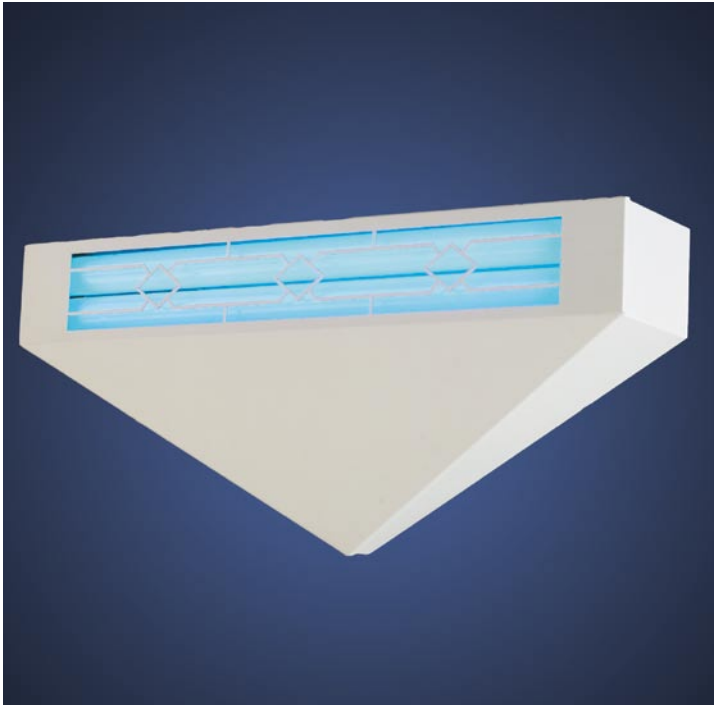

The Gilbert® 2002GT Flying Venus™ provides the same standard setting, fly catching ability of the 2000GT. And, the deeper design holds a large glueboard, flat.

Gilbert® Flying Venus™ wall sconces are serious integrated pest management tools. While not as powerful as our larger traps, these new designs have significantly narrowed that gap, bolstering the overall fly management system.

2002GT features two, superior, 20 watt insect attractant lamps (Sylvania #F20T12/350BL). Replace annually.

Dimensions: 24 3/4" Wide x 11 1/4" High.
Depth slopes from 5 5/8" (at top) to 1 7/16" (at bottom point).
Mount bottom point at least 6' 4" high in halls, corridors, walks, passageways, or isles (See: www.gilbertinc.com/ada.htm).

Textured Vinyl Weight = 8.1 lbs, ShipWt. 10.6 lbs.
Polished / Antique Brass Weight = 10.9 lbs., Ship Wt. 13.3 lbs.

One Year Warranty (excluding lamps & glueboards)

2002GT FLYING VENUS™ CHOICES: Choose decorative power cord (6 ft., 115v grounded) or hard-wire version. We highly recommend ordering the optional hard-wire version for the aesthetic, cordless look. Universal knockouts and keyhole mounting slots provided on all versions.

All Flying Venus™ flytraps are available in four beautiful finishes: Polished Brass, Antique Brass, Textured Black or Textured White, vinyl-coated aluminum.

2002GT Holds Large Glueboard, Flat !!!

Professional
GLUEBOARD
FLYTRAP

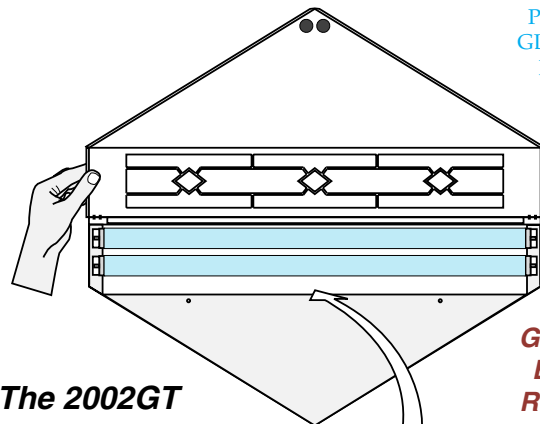

No
Glueboard
Bending
Required !

The 2002GT Holds Large (21-7/8") or Standard (16-7/8" x 4-7/8") Glueboard Flat !!!

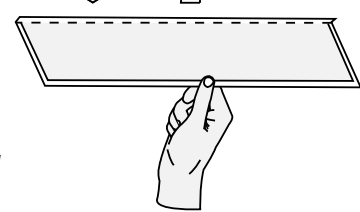

See Also: gilbertinc.com/glueboard.htm

Gilbert® Flying Venus™ wall-sconce flytraps do not depend on wall reflection for effectiveness and will not fade the wall you mount it on!

